



EBARA

ISO 9002
KEMA
CERT. NR. 98922
DUTCH COUNCIL FOR ACCREDITATION



SELF PRIMING PUMP

MODEL SQPB

PT. LUKES INDONESIA

Lindeteves Trade Center Lt UG, Blok B1 No. 6

Jalan Hayam Wuruk, Jakarta - Indonesia

Phone : 021 - 6231 7842, 628 5144

Fax : 021 - 6231 0499

email : lukes@cbn.net.id



APPLICATIONS



Irrigation



Drainage



Sprinklers

FEATURES

1. No priming is required excepting for initial use.
2. Special designed casing provides very rapid priming for extended piping
3. Maintenance is facilitated due to packing type.
4. Water mixed with a little sand or mud can be pumped up due to semi - open impeller design.
5. Easy installation with engine for belt driven due to c.c.w rotation.

SPECIFICATION MODEL SQPB

DISCRIPTION	STANDARD	OPTION
Liquid	Fresh water, river water rain water	sea water
Temperature	0-40°C	
Reg.NPSH	4 m	
Rotation	Counter clockwise when viewed from drive end	
Installation	Outdoors	
Material		
Casing	Cast iron	Bronze
Impeller	Cast iron	Bronze
Shaft	Carbon steel	Stainless steel
Constraction		
Impeller	Semi open	
Stuffing box	Packing	
Bearing	Sealed ball bearing	
Accessories	Strainer, Discharge elbow Hose clamp, Suction hose nipple Standard V - pulley	

SELECTION OF THE PUMP CALCULATION FOR PADDY FIELD

Water Consumption of paddy field is 60 l/min/Ha

Example : Paddy field : 5 Ha

what is the model of pump

Pump head: 10 m

Result : water consumption (Q) : 5 Ha x 60 l/min/Ha
: 300 l/min = 0.3 m³/min

The pump model is 50 SQPB

SECTIONAL VIEW

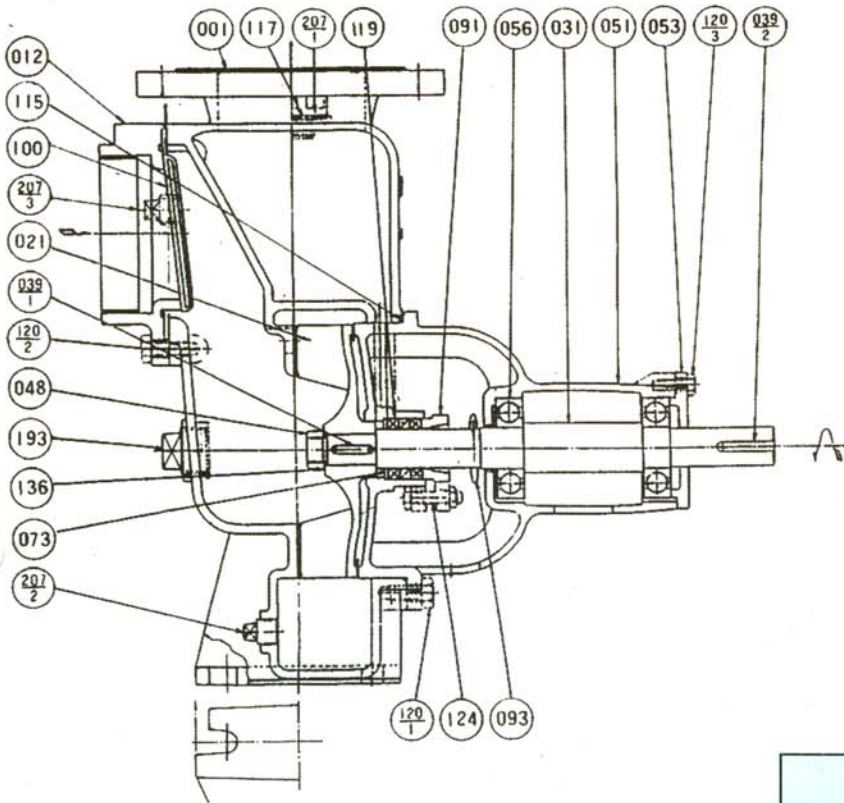

207 - 3	PLUG	CAST IRON	1
207 - 2	DRAIN PLUG	CAST IRON	1
207 - 1	PRIMING PLUG	PLASTIC	1
193	PLUG	CAST IRON	2
136	WASHER	BRASS	1
124	GLAND BOLT AND NUT	STEEL	1
120 - 3	BOLT	STEEL	2
120 - 2	SUCTION COVER BOLT	STEEL	3
120 - 1	CASING BOLT	STEEL	4
119	GLAND PACKING	ASBESTOS	3
117	GASKET	RUBBER	1
115	O-RING	NBR	1
100	CHECK VALVE	RUBBER	1
093	DEFLECTOR	NBR	1
091	GLAND	CAST IRON	1
073	STAGE PIECE	STEEL	1
056	BALL BEARING	-	2
053	BEARING COVER	CAST IRON	1
051	BEARING HOUSING	CAST IRON	1
048	IMPELLER NUT	BRASS	1
039 - 2	KEY	CARBON STEEL	1
039 - 1	KEY	CARBON STEEL	1
031	SHAFT	CARBON STEEL	1
021	IMPELLER	CAST IRON	1
012	SUCTION COVER	CAST IRON	1
001	CASING	CAST IRON	1
PART NO	PART NAME	MATERIAL	NO.FOR 1 UNIT



SEMI OPEN IMPELLER

OTHER



PUMP COUPLED WITH ENGINE

* This picture doesn't show belt cover.
for safety belt cover should be install.

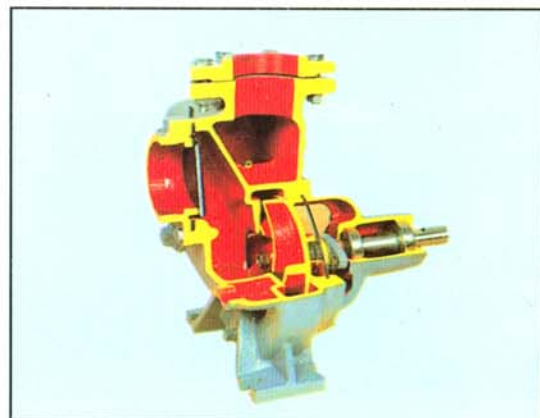

CUT MODEL

BARE SHAFT PUMP DIMENSIONS

50 SQPB

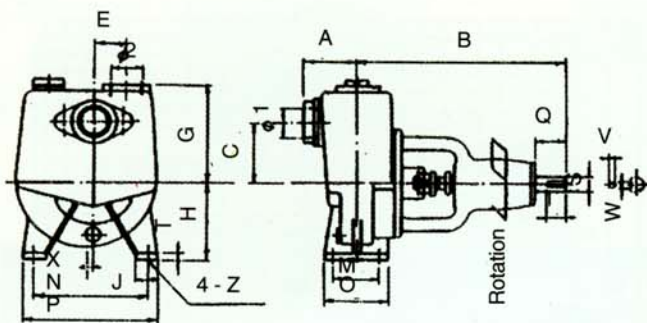

80 SQPB

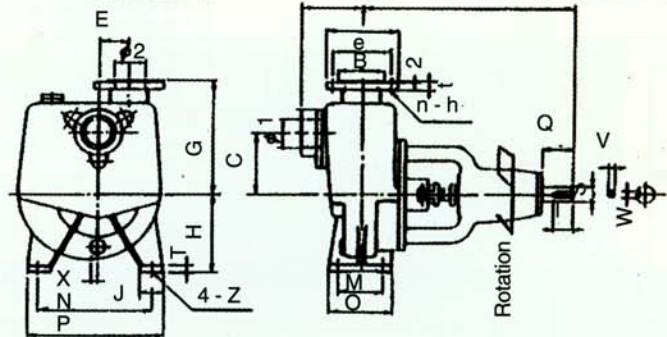

100 SQPB

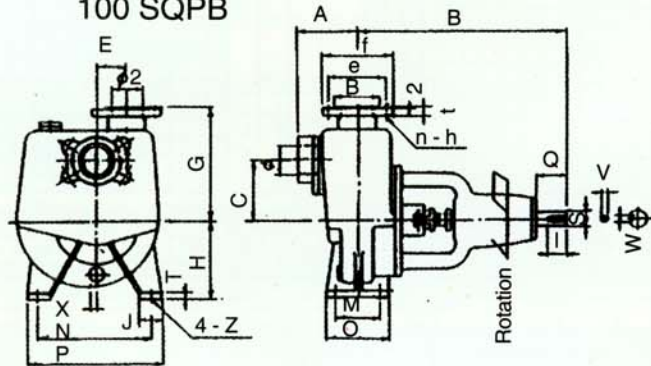

150 SQPB

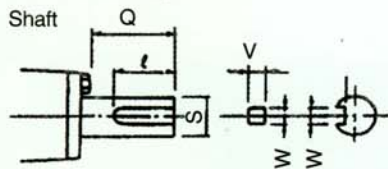
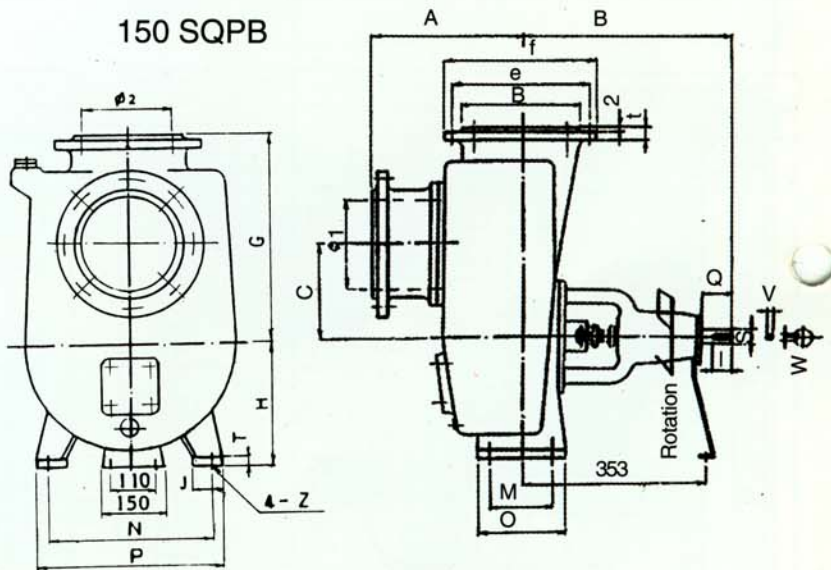

Unit:mm

MODEL	Ø2	g	e	f	t	n	h
50 SQPB	PS-2	-	-	-	-	-	-
80 SQPB	PS-3	130	150	185	18	4	15
100 SQPB	PS-4	155	175	210	20	4	15
150 SQPB	150	215	240	280	22	8	19

Unit:mm

MODEL	Pump															Shaft End					Weight (Mass) Kg
	Ø1	A	B	C	E	G	H	J	T	M	N	O	P	X	Z	S	Q	I	V	W	
50 SQPB	PS-2	100	240	100	40	165	112	35	10	50	150	80	180	0	12	19	34	27	6	6	17
80 SQPB	PS-3	120	275	120	25	225	132	40	12	70	190	100	230	10	12	24	50	40	8	7	27
100 SQPB	PS-4	130	330	155	25	275	160	50	12	100	230	140	280	20	15	28	55	50	8	7	42
150 SQPB	150	280	470	180	-	400	225	80	16	120	315	160	400	-	19	32	80	68	8	10	130

PERFORMANCE CURVE

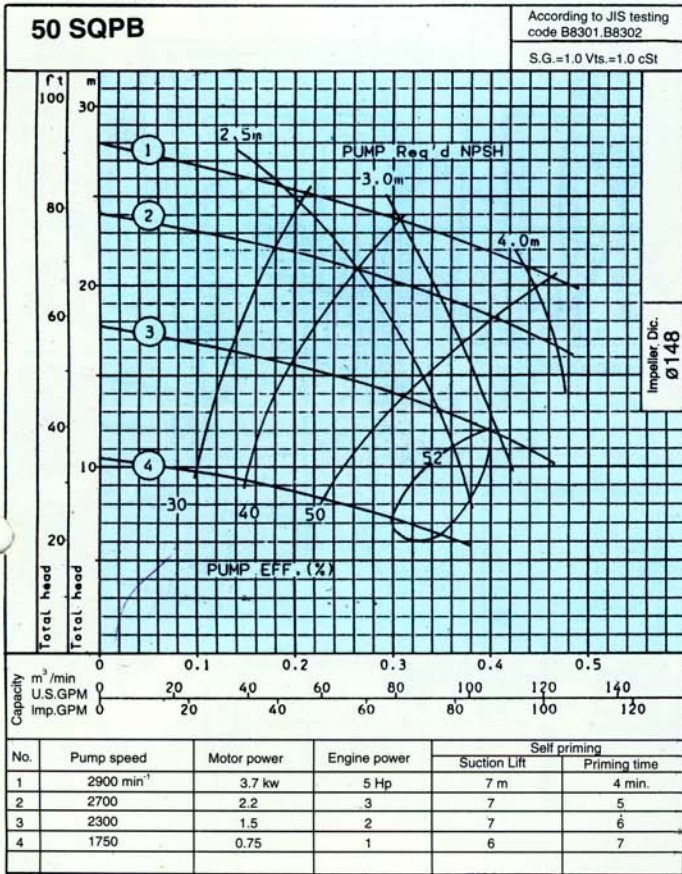

SQPB5401

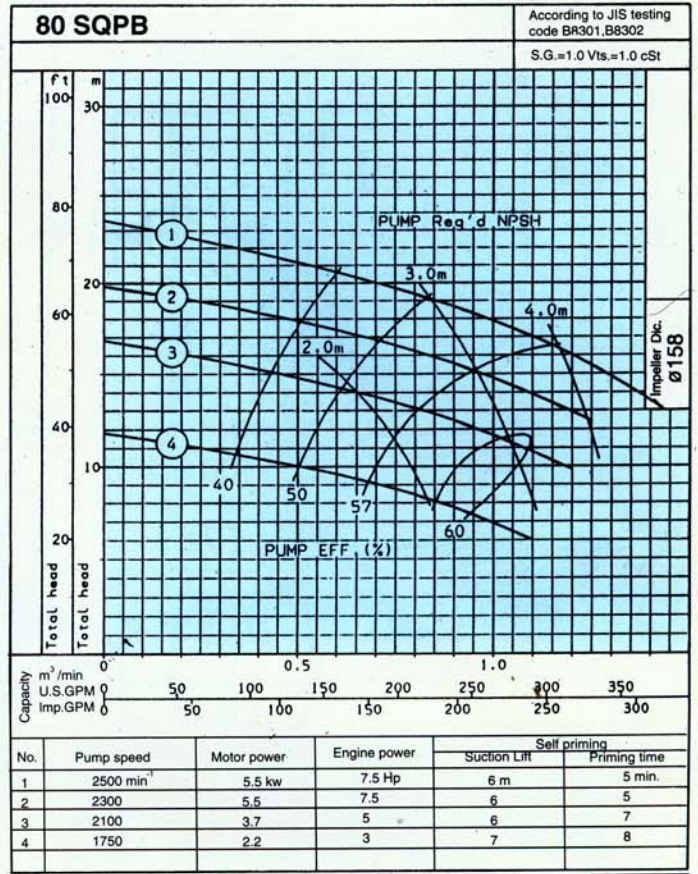

SQPB5402

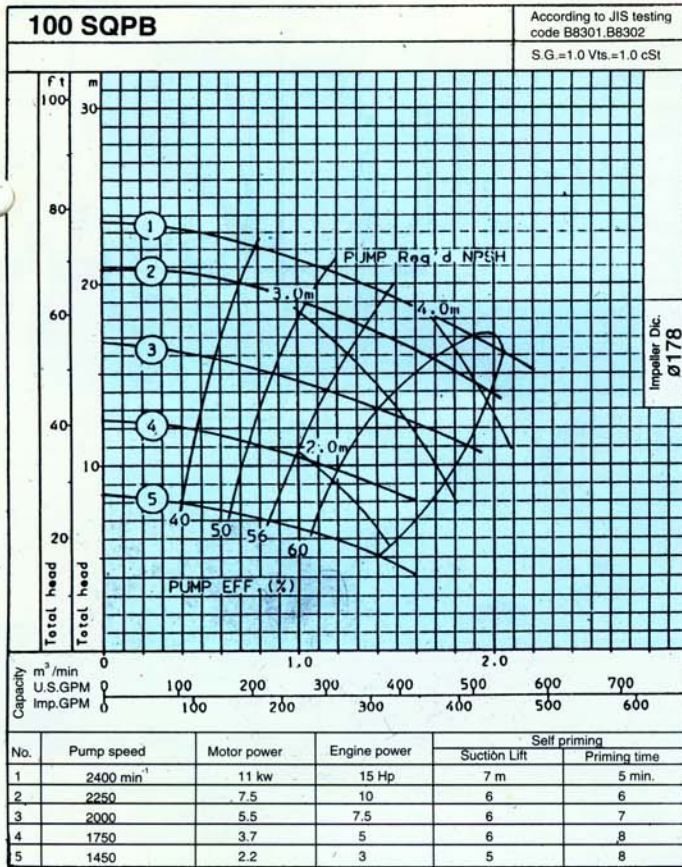

SQPB5403

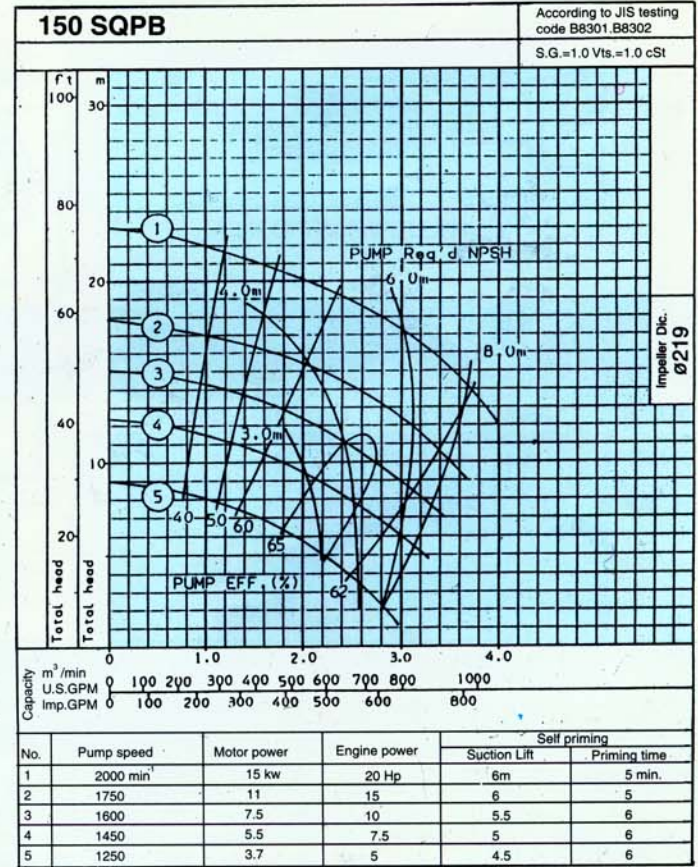

SQPB5404

DISASSEMBLY

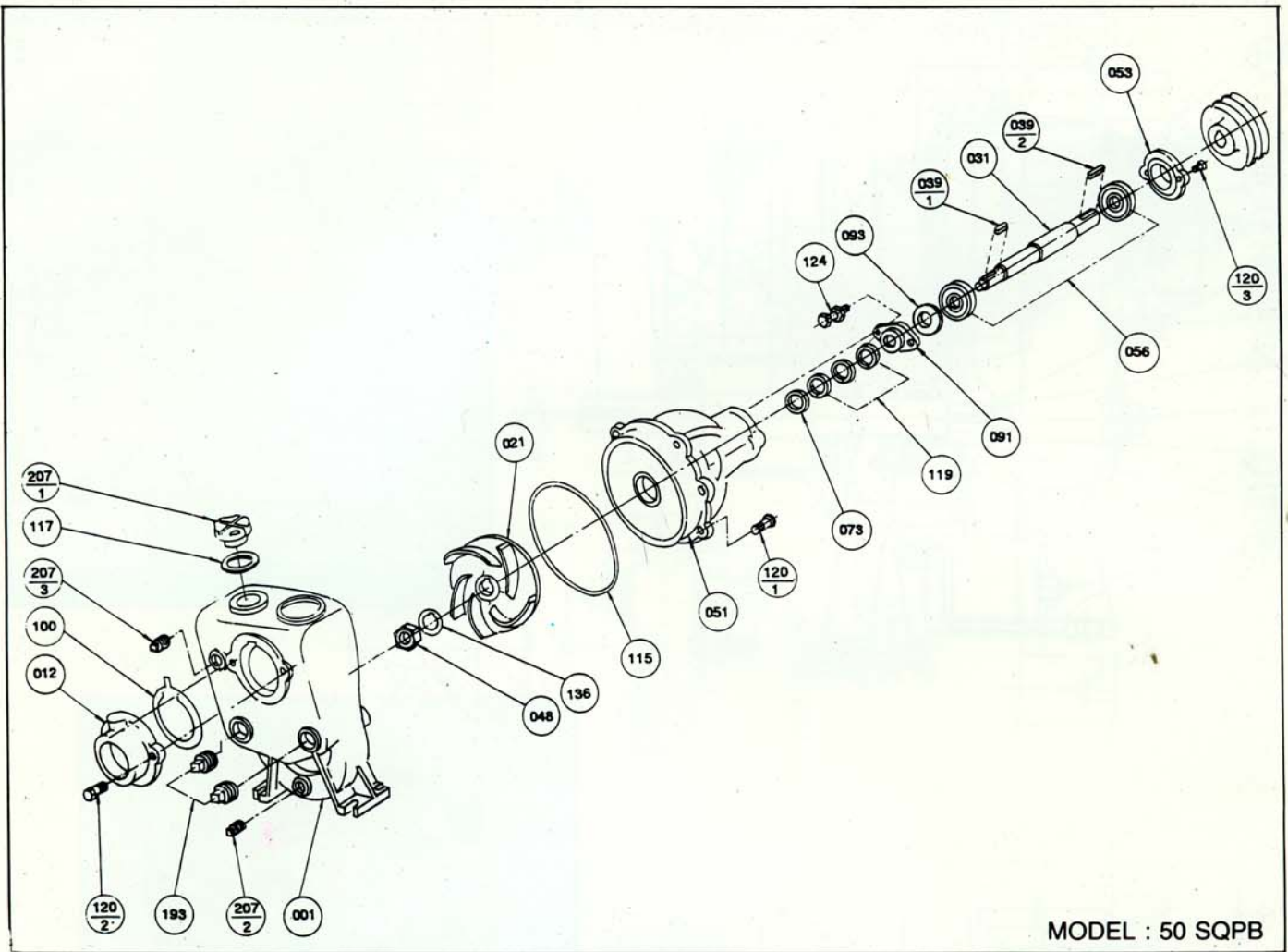

All specifications are subject to change without notice

